

4

3

2

1

REVISION HISTORY				
ZONE	REV	DESCRIPTION	DATE	APPROVED
	1	INITIAL RELEASE	04/28/2011	

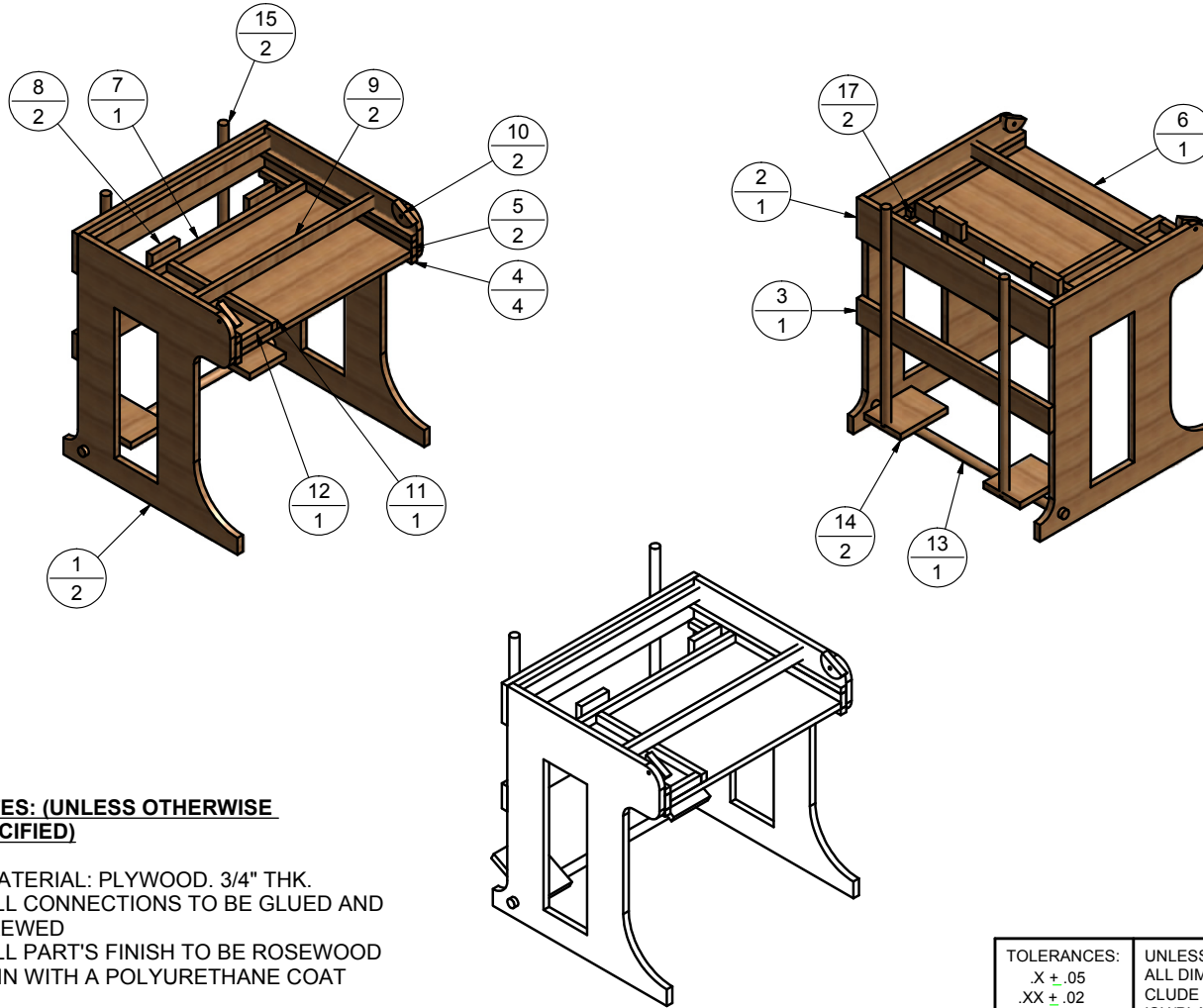

ITEM	QTY	PART NAME	DESCRIPTION
17	2	K STOP 3	SEE SHEET 4
16	1	TABLE TOP	SEE SHEET 4
15	2	ROD R	SEE SHEET 4
14	2	PEDAL 1	SEE SHEET 4
13	1	BOTTOM ROD	SEE SHEET 4
12	1	K SCALE BOX 2 - 2	SEE SHEET 4
11	1	K SCALE BOX	SEE SHEET 3
10	2	ROUND 1	SEE SHEET 3
9	2	R FRAME	SEE SHEET 3
8	2	K STOP 1	SEE SHEET 3
7	1	K BACK	SEE SHEET 3
6	1	K BOTTOM	SEE SHEET 3
5	2	K L SIDE	SEE SHEET 2
4	4	K RAIL 1 - 4	SEE SHEET 2
3	1	T 2 BACK	SEE SHEET 2
2	1	T 1 BACK	SEE SHEET 2
1	2	TABLE LEG	SEE SHEET 2

Parts List

**NOTES: (UNLESS OTHERWISE SPECIFIED)**

1. MATERIAL: PLYWOOD. 3/4" THK.
2. ALL CONNECTIONS TO BE GLUED AND SCREWED
3. ALL PART'S FINISH TO BE ROSEWOOD STAIN WITH A POLYURETHANE COAT

<b>TOLERANCES:</b> .X + .05 .XX + .02 .XXX + .01 .XXXX + .005 ANGLES ± 1°	UNLESS OTHERWISE NOTED: ALL DIMS IN INCHES & IN- CLUDE CHEM. APPLIED FIN- ISH/PLATING. REMOVE ALL BURRS AND SHARP EDGES. DO NOT SCALE DRAWING.		<b>TABLE, ASSY</b>	
	SCALE: 1:12 DATE: 04/28/2001	APPROVED:	DR. BY: F. MORENO REVISED:	
<b>AUSTIN COMMUNITY COLLEGE</b>				
MAT'L:	FINISH:	DFTG1433.	SHEET: 1 OF 4	

4

3

2

1

4

3

↓

2

1

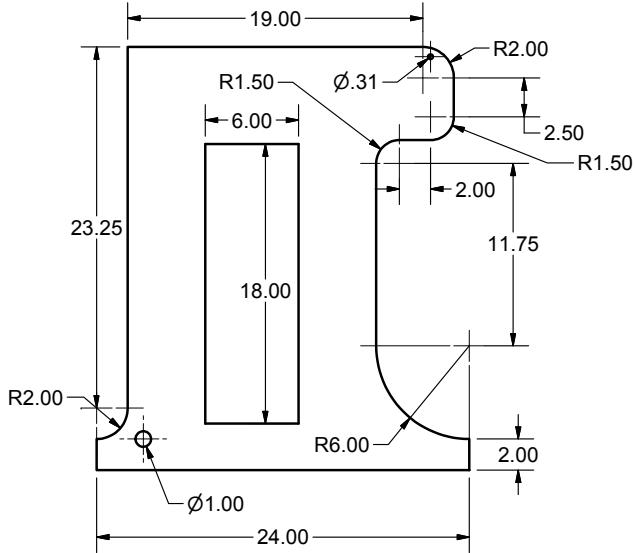

**1. TABLE LEG**

NOTES: 1. TWO REQUIRED

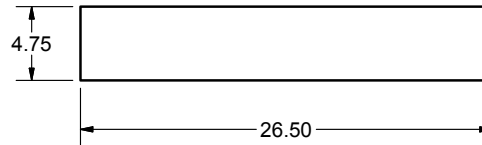

**2. T1 BACK**

NOTES: 1. ONE REQUIRED

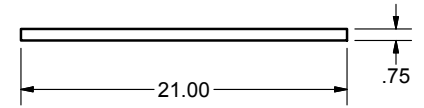

**4. K RAIL 1 - 4**

NOTES: 1. FOUR REQUIRED

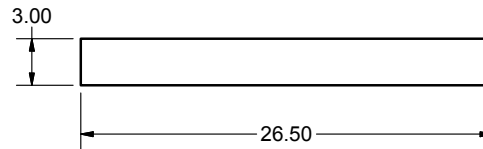

**3. T2 BACK**

NOTES: 1. ONE REQUIRED

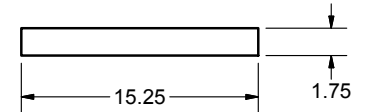

**5. K L SIDE**

NOTES: 1. TWO REQUIRED

<p>TOLERANCES:                  .X ± .05                  .XX ± .02                  .XXX ± .01                  .XXXX ± .005                  ANGLES ± 1'</p>	<p>UNLESS OTHERWISE NOTED:                  ALL DIMS IN INCHES &amp; IN-                  CLUDE CHEM. APPLIED FIN-                  ISH/PLATING. REMOVE ALL                  BURRS AND SHARP EDGES.                  DO NOT SCALE DRAWING.</p>	<b>TABLE ASSY, DETAILS</b>	
		SCALE: 1:8	APPROVED:
		DATE: 05/01/2011	REVISED:
<b>AUSTIN COMMUNITY COLLEGE</b>			
	MAT'L:	FINISH:	DFTG1433.
			SHEET: 2 OF 4

4

3

↑

2

1

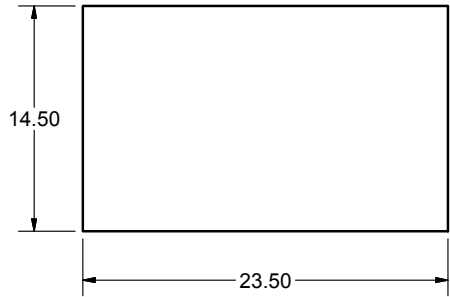

**6. K BOTTOM**  
NOTES: 1. ONE REQUIRED

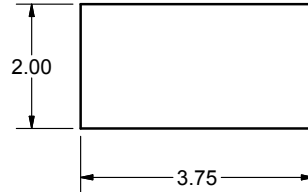

**8. K STOP 1**  
NOTES: 1. TWO REQUIRED  
2. SCALE 1:2

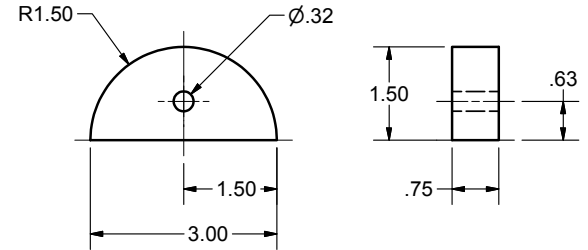

**10. ROUND 1**  
NOTES: 1. TWO REQUIRED  
2. SCALE 1:2

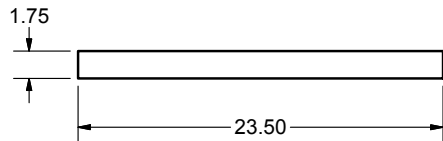

**7. K BACK**  
NOTES: 1. ONE REQUIRED

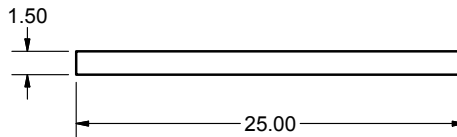

**9. R FRAME**  
NOTES: 1. TWO REQUIRED

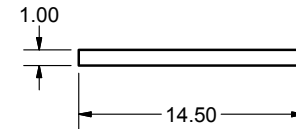

**11. K SCALE BOX**  
NOTES: 1. ONE REQUIRED

<p>TOLERANCES: .X + .05 .XX + .02 .XXX + .01 .XXXX + .005 ANGLES ± 1'</p>	<p>UNLESS OTHERWISE NOTED: ALL DIMS IN INCHES &amp; IN- CLUDE CHEM. APPLIED FIN- ISH/PLATING. REMOVE ALL BURRS AND SHARP EDGES. DO NOT SCALE DRAWING.</p>	<b>TABLE ASSY, DETAILS</b>	
		SCALE: 1:8	APPROVED:
		DATE: 05/01/2011	REVISED:
<b>AUSTIN COMMUNITY COLLEGE</b>			
MAT'L:	FINISH:	DFTG1433.	SHEET: 3 OF 4

4

3

↓

2

1

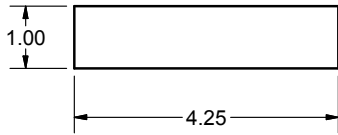

**12. K SCALE BOX 2 - 2**

NOTES: 1. ONE REQUIRED  
2. SCALE 1:2

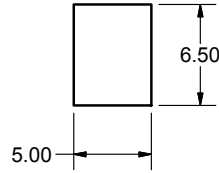

**14. PEDALS**

NOTES: 1. TWO REQUIRED

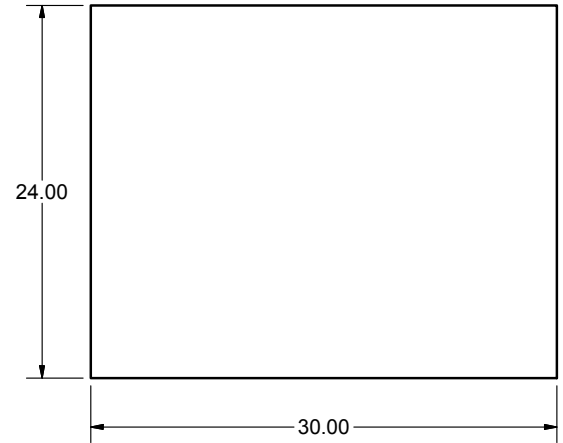

**16. TABLE TOP**

NOTES: 1. ONE REQUIRED

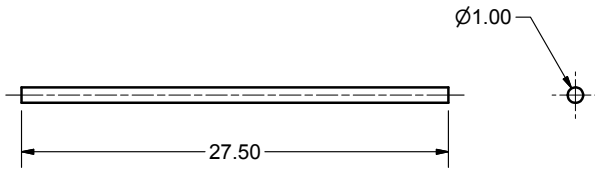

**13. BOTTOM ROD**

NOTES: 1. ONE REQUIRED

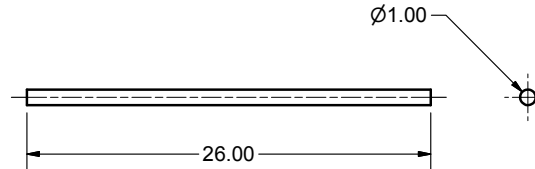

**15. ROD R**

NOTES: 1. TWO REQUIRED

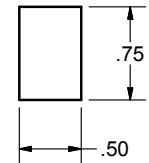

**16. K STOP 3**

NOTES: 1. TWO REQUIRED  
2. SCALE 1:1

<p>TOLERANCES: .X ± .05 .XX ± .02 .XXX ± .01 .XXXX ± .005 ANGLES ± 1'</p>	<p>UNLESS OTHERWISE NOTED: ALL DIMS IN INCHES &amp; IN- CLUDE CHEM. APPLIED FIN- ISH/PLATING. REMOVE ALL BURRS AND SHARP EDGES. DO NOT SCALE DRAWING.</p>	<b>TABLE ASSY, DETAILS</b>	
		SCALE: 1:8	APPROVED:
		DATE: 05/01/2011	REVISED:
<b>AUSTIN COMMUNITY COLLEGE</b>			
MAT'L:	FINISH:	DFTG1433.	SHEET: 4 OF 4

4

3

↑

2

1

4

3



2

1

4  
4

5  
3

2  
1

1  
2

3  
1

6  
2

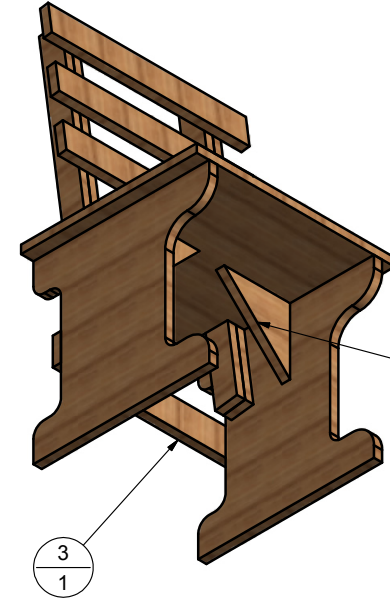

6	2	CH BRACE	SEE SHEET 3
5	3	CH BACK	SEE SHEET 3
4	4	CH VERTICAL BACK	SEE SHEET 2
3	1	CH BASE	SEE SHEET 2
2	1	CH TOP	SEE SHEET 2
1	2	CH R SIDE	SEE SHEET 2
ITEM	QTY	PART NAME	DESCRIPTION

Parts List

<p>TOLERANCES:                  .X + .05                  .XX + .02                  .XXX + .01                  .XXXX + .005                  ANGLES ± 1'</p>	<p>UNLESS OTHERWISE NOTED:                  ALL DIMS IN INCHES &amp; IN-                  CLUDE CHEM. APPLIED FIN-                  ISH/PLATING. REMOVE ALL                  BURRS AND SHARP EDGES.                  DO NOT SCALE DRAWING.</p>	<b>STOOL ASSY</b>	
		SCALE: 1:8	APPROVED:
		DATE: 05/01/2011	REVISED:
<b>AUSTIN COMMUNITY COLLEGE</b>			
MAT'L:		FINISH:	DFTG1433.
			SHEET: 1 OF 3

4

3



2

1

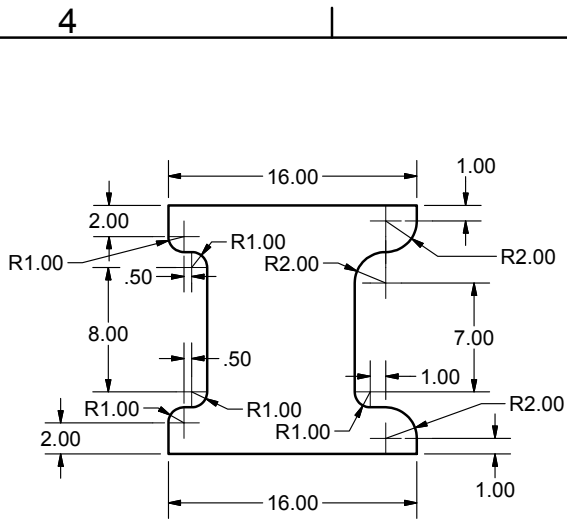

**1. CH R SIDE**

NOTES: 1. TWO REQUIRED

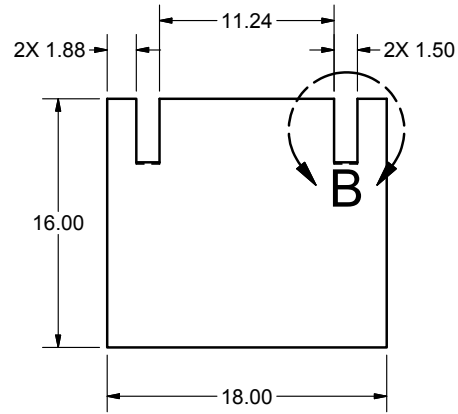

**2. CH TOP**

NOTES: 1. ONE REQUIRED

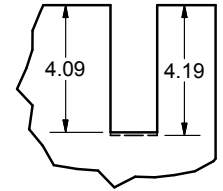
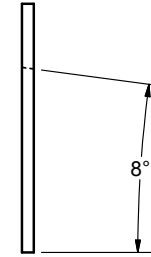

**DETAIL B**  
SCALE 1/4

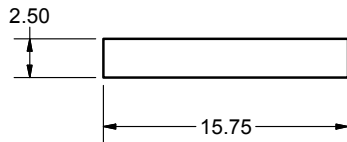

**3. CH BASE**

NOTES: 1. ONE REQUIRED

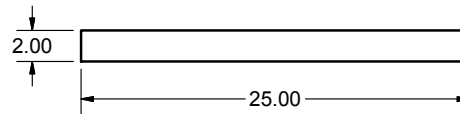

**4. CH VERTICAL BACK**

NOTES: 1. FOUR REQUIRED  
2. 8° DECLINED TOWARDS THE BACK

<p>TOLERANCES: .X + .05 .XX + .02 .XXX + .01 .XXXX + .005 ANGLES ± 1'</p>	<p>UNLESS OTHERWISE NOTED: ALL DIMS IN INCHES &amp; IN- CLUDE CHEM. APPLIED FIN- ISH/PLATING. REMOVE ALL BURRS AND SHARP EDGES. DO NOT SCALE DRAWING.</p>	<p><b>STOOL ASSY, DETAILS</b></p>	
		<p>SCALE: 1:8</p>	<p>APPROVED:</p>
<p>DATE: 05/01/2011</p>		<p>REVISED:</p>	
<p><b>AUSTIN COMMUNITY COLLEGE</b></p>			
<p>MAT'L: </p>	<p>FINISH: </p>	<p>DFTG1433.</p>	<p>SHEET: 2 OF 3</p>

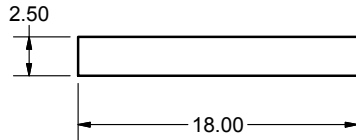

**5. CH BACK**

NOTES: 1. THREE REQUIRED

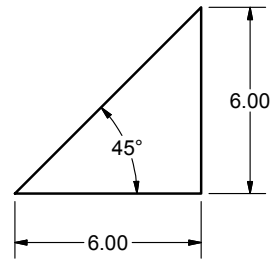

**6. CH BRACE**

NOTES: 1. TWO REQUIRED  
2. SCALE 1:4

<p>TOLERANCES:                  .X ± .05                  .XX ± .02                  .XXX ± .01                  .XXXX ± .005                  ANGLES ± 1'</p>	<p>UNLESS OTHERWISE NOTED:                  ALL DIMS IN INCHES &amp; IN-                  CLUDE CHEM. APPLIED FIN-                  ISH/PLATING. REMOVE ALL                  BURRS AND SHARP EDGES.                  DO NOT SCALE DRAWING.</p>	<b>STOOL ASSY, DETAILS</b>	
		SCALE: 1:8	APPROVED:
		DATE: 05/01/2011	REVISED:
<b>AUSTIN COMMUNITY COLLEGE</b>			
	MAT'L:	FINISH:	DFTG1433.
			SHEET: 3 OF 3